



CARL T.C. GUTIERREZ  
GOVERNOR OF GUAM

Refer to  
Legislative Secretary  
AUG 17 1998

OFFICE OF THE LEGISLATIVE SECRETARY	
RECEIVED	
Received By: <u>Rosenio</u>	
Time: <u>8:45am</u>	
Date: <u>8/18/98</u>	

The Honorable Antonio R. Unpingco  
Speaker  
Mina'Bente Kuáttro na Liheslaturan Guáhan  
Twenty-Fourth Guam Legislature  
Guam Legislature Temporary Building  
155 Hesler Street  
Hagåtña, Guam 96910

Office of the Speaker  
ANTONIO R. UNPINGCO  
Date: 8/17/98  
Time: 11:15 AM  
Rec'd by: [Signature]  
Print Name: ANDREW FRANCIS

Dear Speaker Unpingco:

Enclosed please find Substitute Bill No. 667 (COR), "AN ACT TO ESTABLISH THE VILLAGE NATURE, WATER AND RECREATIONAL THEME PARK DEVELOPMENT PROGRAM AND PILOT PROJECT IN THE MUNICIPALITY OF BARRIGADA, AND TO APPROPRIATE FUNDS TO CARRY OUT THE INITIAL PHASE OF THE PROJECT", which I have signed into law today as **Public Law No. 24-269**.

This legislation supports the concept of creating parks on Guam which are not located near beaches or the coastline, but instead are inland parks near neighborhoods where our people reside. This legislation promotes the creation of an inland park that would accommodate such items as outdoor recreational courts for basketball and tennis, bleachers for spectators, commercial/retail areas and other amenities, bicycling track, botanical garden, man-made pond with fresh water fish, jogging and walking path, picnic grounds, ball fields, and so forth.

Although this legislation is not specific where such a park would be developed, this concept of a botanical garden, nature trails, and recreational facilities for our village neighborhoods which are not located on the coastline is a desirable enhancement for our island lifestyle.

Very truly yours,

[Signature]  
Carl T. C. Gutierrez  
I Maga'lahaen Guáhan  
Governor of Guam

00985

Attachment: copy attached for signed bill  
original attached for vetoed bill

cc: The Honorable Joanne M. S. Brown  
Legislative Secretary

MINA'BENTE KUATTRO NA LIHESLATURAN GUAHAN  
1998 (SECOND) Regular Session

CERTIFICATION OF PASSAGE OF AN ACT TO I MAGA'LAHEN GUAHAN

This is to certify that Substitute Bill No. 667 (COR), "AN ACT TO ESTABLISH THE VILLAGE NATURE, WATER AND RECREATIONAL THEME PARK DEVELOPMENT PROGRAM AND PILOT PROJECT IN THE MUNICIPALITY OF BARRIGADA, AND TO APPROPRIATE FUNDS TO CARRY OUT THE INITIAL PHASE OF THE PROJECT," was on the 3<sup>rd</sup> day of August, 1998, duly and regularly passed.

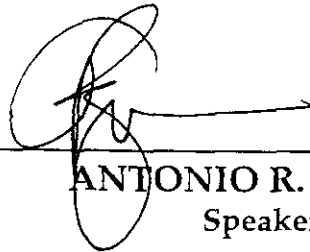
  
ANTONIO R. UNPINGCO  
Speaker

Attested:

  
JOANNE M.S. BROWN  
Senator and Legislative Secretary

-----  
This Act was received by I Maga'lahaen Guahan this 5<sup>th</sup> day of August, 1998,  
at 3:40 o'clock P.M.

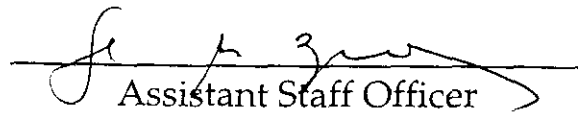
  
Assistant Staff Officer  
Maga'lahaen's Office

APPROVED:

  
CARL T. C. GUTIERREZ  
I Maga'lahaen Guahan

Date: 8-17-98

Public Law No. 24-269

**MINA/BENTE KUATTRO NA LIHESLATURAN GUÅHAN**  
**1998 (SECOND) Regular Session**

**Bill No. 667 (COR)**

As substituted by the Committee  
on Finance and Taxation and as  
amended on the Floor.

Introduced by:

A. C. Blaz  
Felix Camacho  
Mark Forbes  
A. Lamorena V  
C. A. Leon Guerrero  
L. F. Kasperbauer  
T. C. Ada  
F. B. Aguon, Jr.  
J. M.S. Brown  
Francisco P. Camacho  
M. C. Charfauros  
E. J. Cruz  
W. B.S.M. Flores  
L. A. Leon Guerrero  
V. C. Pangelinan  
J. C. Salas  
A. L.G. Santos  
F. E. Santos  
A. R. Unpingco  
J. Won Pat-Borja

**AN ACT TO ESTABLISH THE VILLAGE NATURE, WATER  
AND RECREATIONAL THEME PARK DEVELOPMENT  
PROGRAM AND PILOT PROJECT IN THE MUNICIPALITY  
OF BARRIGADA, AND TO APPROPRIATE FUNDS TO  
CARRY OUT THE INITIAL PHASE OF THE PROJECT.**

1            **BE IT ENACTED BY THE PEOPLE OF GUAM:**

1           **Section 1. Legislative Findings, Declarations and Intent.**           I

2   *Liheslaturan Guåhan* finds that the present Paseo Park, constructed over the  
3   “hard-fill” Paseo De Susana area with what was once the ravaged city of  
4   Hågåtña after World War II, has become a prolific center of Guam’s recreational  
5   and general purpose park activities. Today, thousands of our citizens patronize  
6   this park for recreation, bicycling, jogging, walking, picnicking, exercising and  
7   leisurely enjoying the sunset, cool ocean breeze and the solitude the Paseo Park  
8   has to offer.

9           Because of the popularity of the Paseo Park and the great number of our  
10   people frequenting the place, *I Liheslaturan Guåhan* further finds that crime  
11   incidences, especially drug-related and violent crimes, graffiti and vandalism on  
12   public facilities are virtually curbed or unheard off.

13           Additionally, *I Liheslaturan Guåhan* finds the need for more and better  
14   recreational facilities, as well as parks throughout the Island for use by our  
15   people to be urgent, if for no other reason than to deter our youths from criminal  
16   activities by offering them better alternatives than what they would ordinarily  
17   find in the streets and waywardly plagued areas of our community.

18           Further, *I Liheslaturan Guåhan* finds that Island residents in general are also  
19   demanding park facilities where families with children can go to, as an  
20   alternative to other outlets, and enjoy themselves; a facility that offers safe,  
21   beautiful and sanitary amenities without cost where parents with children can  
22   spend their leisure and quality time as a family unit.

23           *I Liheslaturan Guåhan* declares that it is in the best interest of the people, in  
24   general, and the communities, in particular, to develop multi-purpose  
25   recreational park facilities regionally situated throughout the Island

1 municipalities, and particularly inland to complement coastal beach parks that  
2 would accommodate a gymnasium with basketball court, weight room, locker  
3 and shower facilities, bleachers for spectators, commercial/retail areas, and other  
4 amenities, a bicycling track, a botanical garden, a small man-made pond stocked  
5 with fresh water fish, a jogging and walking path, picnic grounds, ball fields and  
6 other amenities in particular water-related activities where multi recreational  
7 activities can be performed within a wholesome and family oriented park  
8 environment for the mutual enjoyment of all segments of the community.

9 In addition, *I Liheslaturan Guåhan* declares that these recreational park  
10 facilities, collectively or separately located, yet managed and operated in an  
11 integrated manner, will act as village centers of community activities, like Paseo  
12 Park where recreational as well as family oriented activities can be enjoyed  
13 together without conflict, and, at the same time, act as a deterrent to criminal  
14 activities because these recreational park facilities will be regionally situated to  
15 serve the immediate surrounding communities without the need for those  
16 individuals having to travel to Paseo Park or other locations throughout the  
17 Island.

18 Finally, *I Liheslaturan Guåhan* declares that the development of these  
19 recreational park facilities will constitute a good investment of taxpayers money  
20 back to the respective communities and towards this government's war against  
21 crime, especially violent and drug-related crimes that prey on our youths in  
22 particular.

23 It is the intent of *I Liheslaturan Guåhan* to select the Municipality of  
24 Barrigada, which is situated inland away from beach parks, to inaugurate a pilot  
25 project to plan, design and construct a diversified recreational village park

1 facility. Barrigada is ideally situated for the pilot project. It is centrally located.  
2 Land is available and ideal for park condition. On-going plans for development  
3 of a gym can be effectively integrated either on-site or operationally only at the  
4 originally selected and separate location into the broader context of a village  
5 recreational park. The development of a botanical garden, a man-made lake and  
6 nature and recreational trails will provide attractions normally not available  
7 except on coastal settings like Agat, Umatac, Merizo, Inarajan, Talofoyo, Togcha,  
8 Yilig, Ipan, Chalan Pago, Tumon, Tamuning, Hågātñå, Asan and Piti.

9 **Section 2. Authorization and Appropriation.** (a) The Departments  
10 of Land Management (“DLM”) and the Department of Public Works (“DPW”)  
11 are hereby authorized to inaugurate and implement an inland, away from beach  
12 parks, diversified, multi-purpose recreational park facility to complement coastal  
13 beach parks that would accommodate outdoor recreational courts for basketball  
14 and tennis, bleachers for spectators, commercial/retail areas, and other  
15 amenities, a bicycling track, a botanical garden, a small man-made pond stocked  
16 with fresh water fish, a jogging and walking path, picnic grounds, ball fields and  
17 other amenities, in particular water-related activities, where multi-recreational  
18 activities can be performed within a wholesome and family oriented park  
19 environment for the mutual enjoyment of all segments of the community in the  
20 Municipality of Barrigada encompassing the general areas designated in the  
21 preliminary site drawing and any other privately owned lots within the general  
22 areas deemed appropriate for the purpose of this Act and as they may be made  
23 available through land exchange or outright purchase.

1           (b) There is hereby appropriated Two Hundred Thousand Dollars  
2 (\$200,000.00) as initial funding from the General Fund to the Department of Land  
3 Management to inaugurate and implement the intent of this Act.

4           (c) No portion of the appropriation in this Section shall be expended  
5 until the privately owned lots designated in the preliminary site drawing are  
6 made available through land exchange or money is deposited for the outright  
7 purchase for said lots.

2-24-2009



INA'BENTE KUATTRO NA LIHESLATURAN GUAHAN  
Office of the Vice Speaker  
ANTHONY C. BLAZ

Chairman,  
Finance & Taxation

July 13, 1998 ✓

Chairman,  
Ethics & Standards

The Honorable Speaker Antonio R. Unpingco  
Mina'Bente Kuattro na Liheslaturan Guahan  
155 Hesler Street  
Hagatna, Guam 96910

Vice-Chairman,  
Committee on Rules

Member,  
Judiciary, Public Safety &  
Consumer Protection

Dear Mr. Speaker:

Member,  
Natural Resources

Member,  
Tourism, Economic  
Development, & Cultural  
Affairs

The Committee on Finance and Taxation, to which was referred *Bill No. 667(COR)*, "An Act to establish the village nature, water and recreational theme park development program and pilot project in the municipality of Barrigada and appropriate funds to the Departments of Land Management and Public Works to carry out the initial phase of the project", herein reports back with the recommendation **TO DO PASS Bill No. 667(COR)** as substituted by the Committee on Finance and Taxation.

Member,  
Transportation,  
Telecommunications &  
Micronesian Affairs

Votes of the committee members are as follows:

Member,  
Guam Finance  
Commission

Member,  
Commission on Self  
Determination

10 To Pass

\_\_\_ Not to Pass

\_\_\_ To Place in Inactive File

1 Abstain

\_\_\_ Off-Island

\_\_\_ Not Available

A copy of the committee's report and other pertinent documents are enclosed for your reference and information.

**ANTHONY C. BLAZ**

attachments



# COMMITTEE ON FINANCE & TAXATION











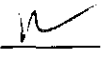
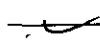
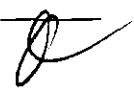
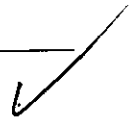
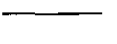





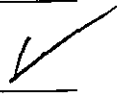

MINA'BENTE KUÁTTRO NA LIHESLATURAN GUÁHAN

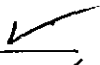
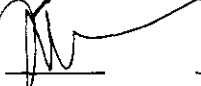
155 Hesler Street, Hagåtña, Guam 96910

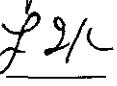
**Chairman: Vice Speaker Anthony C. Blaz    Vice Chairman: Senator Mark Forbes**  
**Ex-Officio Member: Speaker Antonio R. Unpingco**

## VOTING SHEET ON:

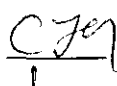
*Substitute Bill No. 667(COR) "An Act to establish the village nature, water and recreational theme park development program and pilot project in the municipality of Barrigada and appropriate funds to the Departments of Land Management and Public Works to carry out the initial phase of the project".*

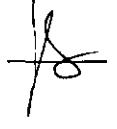
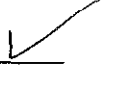
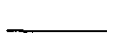
<u>COMMITTEE MEMBERS</u>	<u>INITIAL</u>	<u>TO PASS</u>	<u>NOT TO PASS</u>	<u>ABSTAIN</u>	<u>TO PLACE IN INACTIVE FILE</u>
Sen. Anthony C. Blaz <i>Chairman</i>			<input type="checkbox"/>	<input type="checkbox"/>	<input type="checkbox"/>
Sen. Mark Forbes <i>Vice-Chairman</i>			<input type="checkbox"/>	<input type="checkbox"/>	<input type="checkbox"/>
Spkr. Antonio R. Unpingco <i>Ex-Officio Member</i>			<input type="checkbox"/>	<input type="checkbox"/>	<input type="checkbox"/>
Sen. Thomas C. Ada <i>Member</i>			<input type="checkbox"/>	<input type="checkbox"/>	<input type="checkbox"/>
Sen. Joanne M.S. Brown <i>Member</i>		<input type="checkbox"/>	<input type="checkbox"/>	<input type="checkbox"/>	<input type="checkbox"/>
Sen. Mark Charfauros <i>Member</i>			<input type="checkbox"/>	<input type="checkbox"/>	<input type="checkbox"/>
Sen. Edwardo J. Cruz <i>Member</i>			<input type="checkbox"/>	<input type="checkbox"/>	<input type="checkbox"/>
Sen. Felix P. Camacho <i>Member</i>			<input type="checkbox"/>	<input type="checkbox"/>	<input type="checkbox"/>
Sen. William B.S.M. Flores <i>Member</i>			<input type="checkbox"/>	<input type="checkbox"/>	<input type="checkbox"/>
Sen. Lawrence F. Kasperbauer <i>Member</i>			<input type="checkbox"/>	<input type="checkbox"/>	<input type="checkbox"/>
Sen. Alberto A.C. Lamorena, V <i>Member</i>			<input type="checkbox"/>	<input type="checkbox"/>	<input type="checkbox"/>
Sen. Carlotta A. Leon Guerrero <i>Member</i>			<input type="checkbox"/>	<input type="checkbox"/>	<input type="checkbox"/>
Sen. John C. Salas <i>Member</i>		<input type="checkbox"/>	<input type="checkbox"/>		<input type="checkbox"/>
Sen. Francis E. Santos <i>Member</i>		<input type="checkbox"/>	<input type="checkbox"/>	<input type="checkbox"/>	<input type="checkbox"/>



## ***Committee on Finance & Taxation***

*Vice Speaker Anthony C. Blaz, Chairman*

---

### ***Committee Report***

#### ***Bill No. 667(COR)***

***"An Act to establish the village nature, water and recreational theme park development program and pilot project in the municipality of Barrigada and appropriate funds to the Departments of Land Management and Public Works to carry out the initial phase of the project".***

## **I. OVERVIEW:**

The Committee on Finance and Taxation held a public hearing on Wednesday, July 8, 1998 at 2:00 p.m. in the legislative public hearing room to hear public testimony on *Bill No. 667 (COR)*. Pursuant to the requirements of Public Law 24-109, a reminder memorandum was sent on Monday, June 22, 1998. Additionally, a public hearing notice was published in the Pacific Daily News on Thursday, July 2, 1998 and on Tuesday, July 7, 1998.

## **II. COMMITTEE MEMBERS PRESENT:**

The hearing was called to order by the Chairman of the Committee on Finance and Taxation, Vice Speaker Anthony C. Blaz.

Other members of the Committee on Finance and Taxation present were:

*Senator Edwardo Cruz*

Other Senators present were:

*Senator Frank B. Aguon, Jr.*  
*Senator Francisco P. Camacho*

## Providing Publ. Testimony:

*Carl J. C. Aguon, Director, DOLM (written)*

*Nasion Chamoru (written)*

*Chris Howard Perez, Coalition of Chamorro Rights Org. (oral)*

*Vicente L. Leon Guerrero, Vice Mayor, Barrigada (oral)*

*Joseph R. Borja*

*Ronald Teehan, Chamorro Land Trust Commission (will provide written testimony within 10 days)*

*John T. Anderson, Chief Planner (written)*

*Raymond Laguana, Mayor of Barrigada*

### III. BACKGROUND:

#### **Findings:**

Describing the success story of the Paseo de Susana Park in Hagatna, Bill 667(COR) as substituted by the Committee on Finance and Taxation aims to take the landmark experience of Guam's most prolific recreational park as a model for further inland development of water use related and other family and sports recreational facilities under an integrated village park concept.

Other than coastal beach, historical and sports recreational park areas, Guam lacks parks for family recreation, especially inland areas. Bill 667 serves to begin to fill this void through a pilot park development in the village of Barrigada.

The pilot project envisioned will take advantage of an area generally flood prone and serving as a drainage and ponding basin for the configuration of a small man-made recreational lake, landscaping of a botanical garden, configuring jogging, walking and biking trails and construction of numerous outdoor sports facilities as well as picnic areas with other essential and practical

Badminton

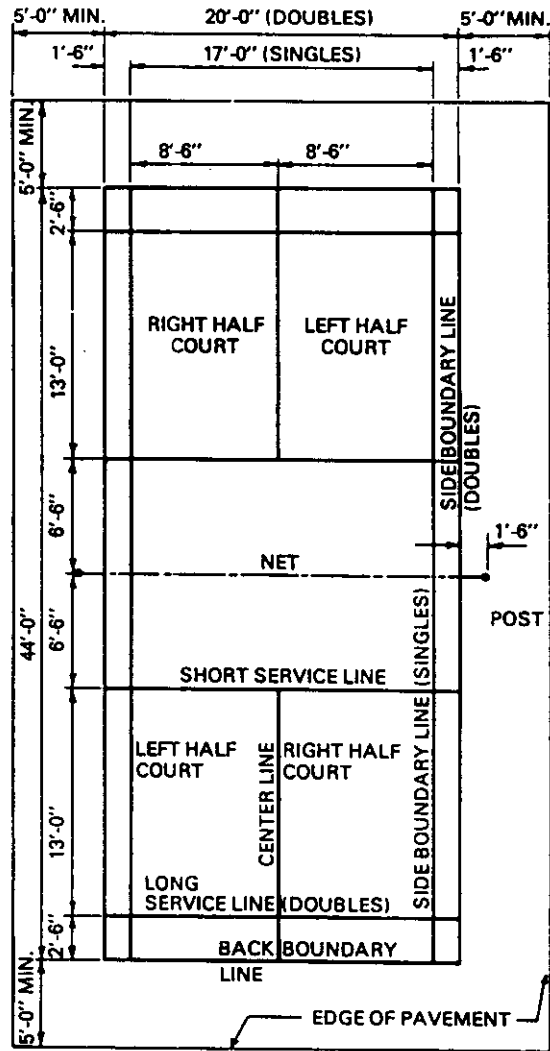

(a)

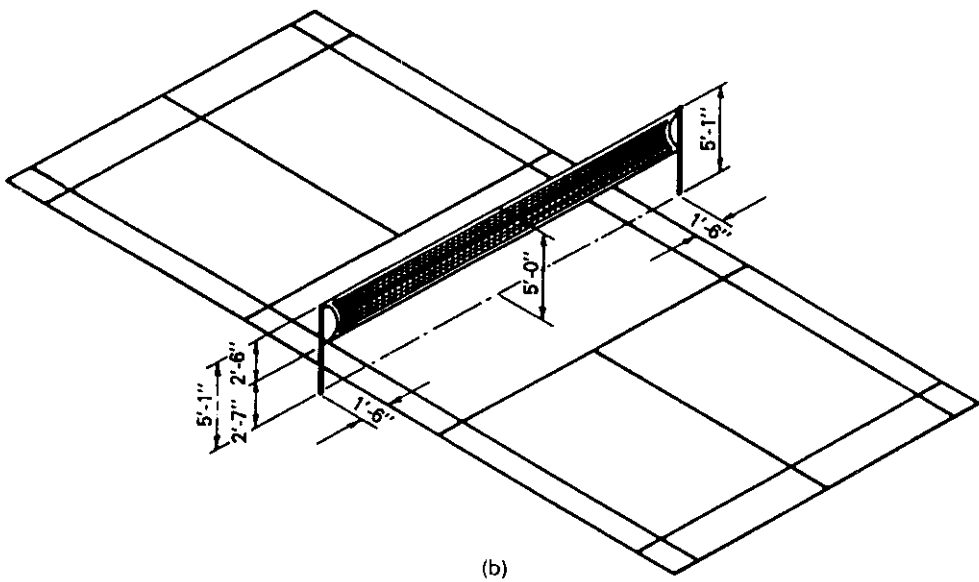

(b)

Figure 5.26 Badminton: (a) court layout; (b) isometric showing net.



Bicycling: Track Layouts

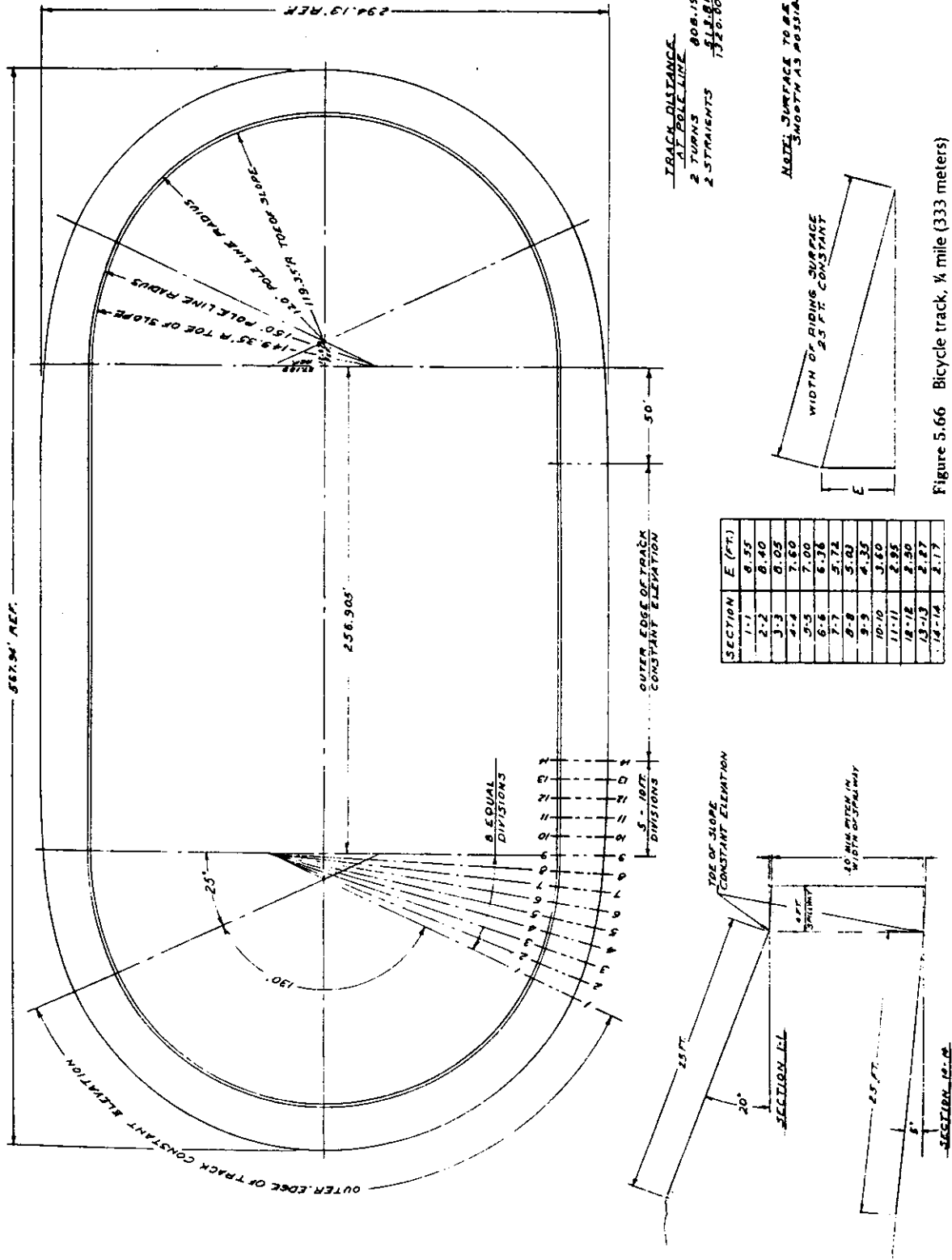

Figure 5.66 Bicycle track, 1/4 mile (333 meters)

amenities. The area in question would normally end up in a drainage and ponding basin configuration.

With the scarcity of land, the government is learning to convert to better ancillary use such naturally restricted land areas such as the siting of the Guam Visitors Bureau and the Sagan Policia, near the Palace Hotel, over ponding basins.

If successful, other parks can be sited, designed and constructed for other villages in particular those away from the coast. Such parks can attract families throughout the year, for picnics and outdoor water related or sports recreation to include yard games, kite flying, canoeing or kayaking, basketball, tennis, baseball or softball, biking, jogging or hiking, among a few. Besides instilling village or community pride, the overall quality of life and mental and physical health of residents can be enhanced at the village level.

The vision of this Bill can be to turn around Guam's recreational value throughout the island beyond just partially beneficial sports facilities at the turn of the century.

#### **SUMMARY OF TESTIMONIES:**

Barrigada Mayor, Raymond Laguana and Vice-Mayor Vicente L. Leon Guerrero testified in favor of Bill 667 on the condition that the gymnasium funded under Public Law Number 24-204 remains a separate project at the originally selected site.

The Director of the Department of Land Management Carl Aguon testified in strong support of the Bill citing the feasibility and



merits of the work described in the Bill. The Department's Chief Planner also testified in favor of the Bill.

Nasion Chamoru was opposed to the Bill because it will diminish the inventory of the Chamorro Land Trust. Chris Perez Howard further testified reiterating this point. Vice Speaker Tony Blaz, Chairman of the Committee, indicated that the proposed land exchange with a lot in Barrigada Heights contained in the Bill was consistent with the Governor's previous submission for settlement on the land taking of Mrs. Frances Cepeda. Director Aguon further emphasized that any government initiated land exchange must be value for value and that the interest of the people of Guam over government land must be protected.

Overall, there is prevailing support of the Bill on the condition that the Barrigada gymnasium be worked on immediately and separately. Also, the necessary land exchanges must be handled in a manner that is fair and reasonable and the interests of parties concerned balanced out.

#### **COMMITTEE RECOMMENDATION:**

The Committee, having conducted a sufficient hearing, recommends reporting out and passage of Bill 667(COR) as substituted by the Committee on Finance and Taxation.



**DEPARTMENT OF LAND MANAGEMENT  
(DIPATTAMENTON TANO')**

*Government of Guam  
P.O. Box 2950  
Agana, Guam 96910*



**CARL T. C. GUTIERREZ**  
*Governor*

**Tel: (671) 475-LAND • Fax: (671) 477-0883**

**CARL J. C. AGUON**  
*Director*

**MADELEINE Z. BORDALLO**  
*Lieutenant Governor*

**FRANCISCO P. SAN NICOLAS**  
*Deputy Director*

Hon Anthony C. Blaz  
Chairman  
Committee on finance and Taxation  
24<sup>th</sup> Guam Legislature  
155 Hesler Street  
Hagatna, Guam 96910

Re: Comments of Bill No. 667 "AN ACT TO ESTABLISH THE VILLAGE NATURE, WATER AND RECREATIONAL THEME PARK DEVELOPMENT PROGRAM AND PILOT PROJECT IN THE MUNICIPALITY OF BARRIGADA ..."

Hafa Adai Senadot Blaz:

The department is pleased to support Bill No. 667 as presented. With the growth of Barrigada's population, there is a definite need for additional recreational facilities that what currently exists.

The approach of proposing a holistic development for the residents of Barrigada that most certainly will appeal to all ages rather than just the young and/or sports minded individuals is an exceptional act on the part of the 24<sup>th</sup> Legislature.

In line with this approach, the Department of Land Management has developed a preliminary sketch of a proposed village theme park. We have also identified the proposed site, to include lot numbers, acreage and ownership.

The Department of Land Management is ready to proceed with contacting the owners of the lots to be affected, for acquisition of these lots, in order to move ahead in developing the village theme park.

As such, we are in full support of the passage of Bill No. 667 and are prepared and anxious to do its part in carrying the development of the Barrigada Village Theme Park.

Thank you for the opportunity to comment on Bill No. 667.

Sincerely,  
  
**CARL J. C. AGUON**  
Director  
Department of Land Management



**NASION CHAMORU**  
**P.O. BOX 1609**  
**HAGATNA, GUAM 96932**  
**TEL: (671) 734-9017**

Hafa adai!  
 Honorable SENATORS

July 8, 1998

Re: Bill# 667

We are just totally fascinated by how promises are made then easily broken. We hear our leaders proclaiming never again would anyone ever deminish the inventory of the Chamoru Land Trust, but in that same breath draft bills that would do just that! The bottom line is this, that the Coalition vows to do everything possible to protect and defend Trust Lands. We humbly ask Senators not to give us the justification to protest. Therefore we suggest that the Committee kills this Bill# 667 "IN COMMITTEE! Thank you for your time.

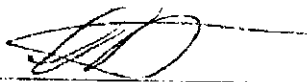

ED L.G. BENAVENTE  
 MAGA' LAHI - NASION CHAMORU

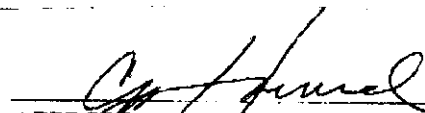

APPROVED BY: CHRIS PEREZ HOWARD  
 ORGANIZATION OF PEOPLE FOR  
 INDIGENOUS RIGHTS

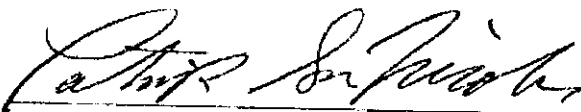

APPROVED BY: PATRICK SAN NICOLAS  
 THE CHAMORU TRIBE OF THE MARIANAS



APPROVED BY: PATRICIA GARIDO  
 THE ANCESTRAL LANDOWNERS COALITION

- cc: 1. Pacific Daily News
- 2. Marianas Variety News
- 3. KUAM News, K-57 & John Anderson
- 4. K-57 & John Anderson

RECEIVED  
 JUL 08 1998  
 1:15 PM



CARL T. C. GUTIERREZ  
*Governor*

**DEPARTMENT OF LAND MANAGEMENT**  
**(DIPATTAMENTON TANO')**

*Government of Guam*  
*P.O. Box 2950*  
*Agana, Guam 96910*

*Tel: (671) 475-LAND • Fax: (671) 477-0883*



CARL J. C. AGUON  
*Director*

MADELEINE Z. BORDALLO  
*Lieutenant Governor*

FRANCISCO P. SAN NICOLAS  
*Deputy Director*

June 3, 1998

Anthony C. Blaz  
Office of the Vice-Speaker  
Twenty-fourth Guam Legislature  
155 Hesler Street  
Agana, Guam 96910

Hafa Adai Senator Blaz,

My staff has done more work on the idea of developing a Barrigada tract into a multi-purpose recreational area. They have prepared a sketch showing all of the cadastral parcels in it. A field inspection was also done from which a general topography layout was included in the sketch. It appears that over two (2) hectares of land may be within the tract. The tract as you know is that low lying area south of your parents home and extending to the Gumabon property at the south end.

We would like to meet with you and discuss this further in light of the data available. The department continues to receive inquiries to exchange lands within this tract. As you know their claim is that the government has made it into a flood basin. While this is disputable, the development of it as a recreational use would certainly justify its acquisition and quiet their voices. May we hear from you soonest.

Senseramente

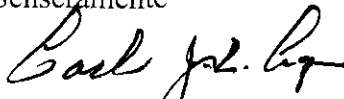
  
CARL J.C. AGUON

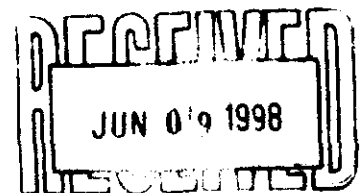

Commonwealth Now!







**MINA'BENTE KUATTRO NA LIHESLATURAN GUAHAN  
COMMITTEE ON FINANCE & TAXATION  
VICE SPEAKER ANTHONY C. BLAZ, CHAIRMAN**

**PUBLIC HEARING**

**JULY 8, 1998 - 2:00 PM  
LEGISLATIVE PUBLIC HEARING ROOM**

**AGENDA**

**CONFIRMATION HEARINGS:**

- Mr. Johnny C. Reyes, Acting Member, Guam Real Estate Commission
- Mr. Joseph R. Ada, Acting Member, Board of Equalization

**PUBLIC HEARING:**

**BILL NO. 614 (J. C. Salas, E. Cruz, L. Kasperbauer)**

**AN ACT TO AMEND P.L. 24-071, TO AUTHORIZE THE GOVERNOR OF GUAM TO SELL ADDITIONAL PORTIONS OF AN ABANDONED PRE-WAR BULL-CART TRAIL IN TALOFOFO TO THE OWNERS OF THE PROPERTY WHICH THE TRAIL ABUTS.**

**BILL NO. 664 (A. C. Blaz)**

**AN ACT TO APPROPRIATE EIGHTY THOUSAND DOLLARS (\$80,000.00) FROM THE GENERAL FUND TO THE DEPARTMENT OF PUBLIC WORKS FOR COMPLETION OF RENOVATION AND REPAIRS OF HAGÁTÑA MAYOR'S OFFICE.**

**BILL 665 (A. C. Blaz)**

**AN ACT TO REPROGRAM AND APPROPRIATE THE RESIDUAL AND EXCESS FUNDS LEFT OVER FROM OTHER CAPITAL IMPROVEMENT PROJECTS, INCLUDING BUT NOT LIMITED TO THE INFRASTRUCTURE DEVELOPMENT BOND, FOR USE TO PLAN, DESIGN, EXPAND AND RECONSTRUCT ROUTE 15, MORE POPULARLY KNOWN AS THE "BACK ROAD TO ANDERSEN".**

**BILL NO. 667 (A. C. Blaz, Fx P. Camacho, M. Forbes, A. Lamorena V, C. Leon Guerrero)**

**AN ACT TO ESTABLISH THE VILLAGE NATURE, WATER AND RECREATIONAL THEME PARK DEVELOPMENT PROGRAM AND PILOT PROJECT IN THE MUNICIPALITY OF BARRIGADA AND APPROPRIATE FUNDS TO THE DEPARTMENTS OF LAND MANAGEMENT AND PUBLIC WORKS TO CARRY OUT THE INITIAL PHASE OF THE PROJECT.**

**BILL NO. 668 (A. C. Blaz, M. Forbes, A. Lamorena V, J.M.S. Brown, C. Leon Guerrero)**

**AN ACT TO AMEND §22425, CHAPTER 22, ARTICLE 4, DIVISION 2 OF TITLE 5 GUAM CODE ANNOTATED (GCA) BY ADDING A NEW SUBSECTION (f) TO AUTHORIZE THE GOVERNOR TO BORROW FROM ANY LENDING INSTITUTION, INCLUDING BUT NOT LIMITED TO THE DEPARTMENT OF AGRICULTURE, RURAL DEVELOPMENT, GENERAL OBLIGATION LOANS FOR THE PURPOSE OF FUNDING THE COST OF DESIGN, PLANS, AND CONSTRUCTION OF THE DEDEDO PRECINCT AND THE CRIME LAB OF THE GUAM POLICE DEPARTMENT AND TO APPROPRIATE SUCH FUNDS ACCORDINGLY.**

**BILL NO. 685 (A. C. Blaz)**

**AN ACT TO APPROPRIATE FUNDS TO THE DEPARTMENT OF PARKS AND RECREATION'S OFF-ISLAND TRAVEL FUND TO SUBSIDIZE THE COST AIR TRAVEL FOR THE BABE RUTH AND THE BAMBINOS LITTLE LEAGUE.**

**BILL NO. 686 (A. C. Blaz, V. C. Pangelinan, A. R. Unpingco)**

**AN ACT TO APPROPRIATE FROM THE VETERAN'S BONUS FUND TO THE NATIONAL ASSOCIATION FOR UNIFORMED SERVICES (NAUS) FOR THE COST TO REPAIR THE VANDALIZED NAUS MEMORIAL AT ASAN POINT DEDICATED TO THE FIGHTING MEN OF THE UNIFORMED SERVICES WHO GAVE THE SUPREME SACRIFICE FOR THE DEFENSE OF THEIR COUNTRY AND THE RECAPTURE OF GUAM DURING WWII.**

**BILL NO. 687 (A. C. Blaz)**

**AN ACT TO CLEARLY IDENTIFY THE SOURCE OF FUNDS APPROPRIATED TO THE SUPERIOR COURT OF GUAM IN PUBLIC LAW NUMBER 24-139.**



Pacific Daily News, Thursday, July 2, 1998 \$4



### NOTICE OF PUBLIC HEARING

Committee on Finance & Taxation  
Vice Speaker Anthony C. Blaz, Chariman  
MINA' BENTE KU'ATRO NA LIHESLATURAN GU'AHAN  
155 HESLER ST. HAGATNA, GUAM 96910

**Wednesday, July 8, 1998**  
LIHESLATURAN GU'AHAN, PUBLIC HEARING ROOM

#### 10:00 AM: Roundtable Meeting

Bill No. 547: AN ACT TO AMEND TITLES 7, 9, AND 19 OF THE GUAM CODE ANNOTATED (GCA) RELATIVE TO THE ENACTMENT OF THE "ERICA'S LAW OR THE FAMILY VIOLENCE ACT OF 1998".

#### 1:30 PM: Public Hearing

##### CONFIRMATION HEARINGS:

Mr. Johnny C. Reyes, Acting Member, Guam Real Estate Commission  
Mr. Joseph R. Ada, Acting member, Board of Equalization

Bill No. 614: AN ACT TO AMEND P.L. 24-071, TO AUTHORIZE THE GOVERNOR OF GUAM TO SELL ADDITIONAL PORTIONS OF AN ABANDONED PRE-WAR BULL-CART TRAIL IN TALOFOFO TO THE OWNERS OF THE PROPERTY WHICH THE TRAIL ABUTS.

Bill No. 665: AN ACT TO REPROGRAM AND APPROPRIATE THE RESIDUAL AND EXCESS FUNDS LEFT OVER FROM OTHER CAPITAL IMPROVEMENT PROJECTS, INCLUDING BUT NOT LIMITED TO THE INFRASTRUCTURE DEVELOPMENT BOND, FOR USE TO PLAN, DESIGN, EXPAND AND RECONSTRUCT ROUTE 15, MORE POPULARLY KNOWN AS THE "BACK ROAD TO ANDERSEN".

Bill No. 664: AN ACT TO APPROPRIATE EIGHTY THOUSAND DOLLARS (\$80,000.00) FROM THE GENERAL FUND TO THE DEPARTMENT OF PUBLIC WORKS FOR COMPLETION OF RENOVATION AND REPAIRS OF HAGATNA MAYOR'S OFFICE.

Bill No. 667: AN ACT TO ESTABLISH THE VILLAGE NATURE, WATER AND RECREATIONAL THEME PARK DEVELOPMENT PROGRAM AND PILOT PROJECT IN THE MUNICIPALITY OF BARRIGADA AND APPROPRIATE FUNDS TO THE DEPARTMENTS OF LAND MANAGEMENT AND PUBLIC WORKS TO CARRY OUT THE INITIAL PHASE OF THE PROJECT.

Bill No. 668: AN ACT TO AMEND §22425, CHAPTER 22, ARTICLE 4, DIVISION 2 OF TITLE 5 GUAM CODE ANNOTATED (GCA) BY ADDING A NEW SUBSECTION (T) TO AUTHORIZE THE GOVERNOR TO BORROW FROM ANY LENDING INSTITUTION, INCLUDING BUT NOT LIMITED TO THE DEPARTMENT OF AGRICULTURE, RURAL DEVELOPMENT, GENERAL OBLIGATION LOANS FOR THE PURPOSE OF FUNDING THE COST OF DESIGN, PLANS AND CONSTRUCTION OF THE DEDEDO PRECINCT AND THE CRIME LAB OF THE GUAM POLICE DEPARTMENT AND TO APPROPRIATE SUCH FUNDS ACCORDINGLY.

Bill No. 685: AN ACT TO APPROPRIATE FUNDS TO THE DEPARTMENT OF PARKS AND RECREATION OFF-ISLAND SPORTS TRAVEL FUND TO SUBSIDIZE THE COST OF THE AIR TRAVEL FOR THE BABE RUTH AND THE BAMBINOS LITTLE LEAGUE.

Bill No. 686: AN ACT TO APPROPRIATE FROM THE VETERAN'S BONUS FUND TO THE NATIONAL ASSOCIATION FOR UNIFORMED SERVICES (NAUS) FOR THE COST TO REPAIR THE VANDALIZED NAUS MEMORIAL AT ASAN POINT DEDICATED TO THE FIGHTING MEN OF THE UNIFORMED SERVICES WHO GAVE THE SUPREME SACRIFICE FOR THE DEFENSE OF THEIR COUNTRY AND THE RECAPTURE OF GUAM DURING W.W.II.

Bill 687: AN ACT TO CLEARLY IDENTIFY A SOURCE OF FUNDS APPROPRIATED TO THE SUPERIOR COURT OF GUAM IN P.L. 24-139.

The Public is invited to Attend and present written and/or oral testimony.  
Contact the Office of Vice-Speaker Anthony C. Blaz at 472-3557/58/60

REC  
NURSI  
DEPA

Submi  
the da  
work m.  
Correc  
734-3



BII

BID NO.  
BID FOR  
MENT SY  
Federally I  
Records A  
Memorial  
OPENIN  
PLACE: G  
INT  
BID FOR

LEASE OR MONTH-TO-MONTH HOTEL LODGING

## AVAILABLE At The LeoPalace Resort Luxurious Duplexes

3-Bedroom duplex units with gorgeous view on the fairway at the beautiful LeoPalace Resort golf course.

**LEASE** (at least 1 year)

- Unfurnished Unit - \$2,200/month  
Equipped with
- Electric Kitchen Stove
  - Refrigerator
  - Water Heater
  - Venetian Blinds
  - Central A/C

## MONTH-TO-MONTH HOTEL LODGING

Fully Furnished Unit - \$2,500/month

### Unique features:

- 10-megawatt power plant of back-up power for the entire resort and every unit. NO POWER OUTAGES!
- Two-million-gallon water tank of water supply
- 100,000-gallon capacity wastewater treatment plant

### Recreational Facilities:

- Swimming Pool
- Two Tennis Courts
- 3-mile Bike Path/Jogging Course
- Golf course w/local fee

Please call for showing appointment: 471-0001 Ext. 1107  
Monday thru Friday Between 9:00am and 5:00pm  
BHI Realty 637-7431  
Mr. Peter Bruschi - Principal Broker

## TONY ROMA'S FAMOUS FOR RIBS AND A WHOLE LOT MORE!

Restaurante Italiano  
**CAPRICCIOSA**  
GUAM

We are looking for qualified, highly motivated individuals for the following positions.

**LINE COOKS  
KITCHEN HELPERS  
FOOD SERVERS  
BUSSERS  
HOST/TESS**

(Japanese speaker a plus)

Please apply at any of our four locations.  
**NO PHONE CALLS PLS.**

We are an equal opportunity employer.



NOTICE OF

## PUBLIC HEARING

The Committee on Natural Resources will be conducting a Public Hearing on Thursday, July 9, 1998 at 10:00 a.m. at the Legislative Public Hearing Room, 155 Hesler Street, Hagatna on:

**BILL 652 - An act to establish the Guam Hydrologic Survey as a permanent program to be administered by the Water and Energy Research Institute of the Western Pacific University of Guam ;**

**Confirmation of Miriam Gallet  
Member, Board of Directors**

**Guam Environmental Protection Agency.**

**ADA Coordinator:**

**Mrs. Toni Gumataotao at 472-3450/51**

**The public is invited to attend.**



## NOTICE OF PUBLIC HEARING

**Committee on Finance & Taxation**

**Vice Speaker Anthony C. Blaz, Chariman**

**MINA BENTE KUATRO NA LIHESLATURAN GUAHAN  
155 HESLER ST. HAGATNA, GUAM 96910**

**Wednesday, July 8, 1998**

**LIHESLATURAN GUAHAN, PUBLIC HEARING ROOM**

### 10:00 AM: Roundtable Meeting

**Bill No. 547: AN ACT TO AMEND TITLES 7, 9, AND 19 OF THE GUAM CODE ANNOTATED (GCA) RELATIVE TO THE ENACTMENT OF THE "ERICA'S LAW OR THE FAMILY VIOLENCE ACT OF 1998".**

### 1:30 PM: Public Hearing

#### CONFIRMATION HEARINGS:

Mr. Johnny C. Reyes, Acting Member, Guam Real Estate Commission  
Mr. Joseph R. Ada, Acting member, Board of Equalization

**Bill No. 614: AN ACT TO AMEND P.L. 24-071, TO AUTHORIZE THE GOVERNOR OF GUAM TO SELL ADDITIONAL PORTIONS OF AN ABANDONED PRE-WAR BULL-CART TRAIL IN TALOFORO TO THE OWNERS OF THE PROPERTY WHICH THE TRAIL ABUTS.**

**Bill No. 665: AN ACT TO REPROGRAM AND APPROPRIATE THE RESIDUAL AND EXCESS FUNDS LEFT OVER FROM OTHER CAPITAL IMPROVEMENT PROJECTS, INCLUDING BUT NOT LIMITED TO THE INFRASTRUCTURE DEVELOPMENT BOND, FOR USE TO PLAN, DESIGN, EXPAND AND RECONSTRUCT ROUTE 15, MORE POPULARLY KNOWN AS THE "BACK ROAD TO ANDERSEN".**

**Bill No. 664: AN ACT TO APPROPRIATE EIGHTY THOUSAND DOLLARS (\$80,000.00) FROM THE GENERAL FUND TO THE DEPARTMENT OF PUBLIC WORKS FOR COMPLETION OF RENOVATION AND REPAIRS OF HAGATNA MAYOR'S OFFICE.**

**Bill No. 667: AN ACT TO ESTABLISH THE VILLAGE NATURE, WATER AND RECREATIONAL THEME PARK DEVELOPMENT PROGRAM AND PILOT PROJECT IN THE MUNICIPALITY OF BARRIGADA AND APPROPRIATE FUNDS TO THE DEPARTMENTS OF LAND MANAGEMENT AND PUBLIC WORKS TO CARRY OUT THE INITIAL PHASE OF THE PROJECT.**

**Bill No. 668: AN ACT TO AMEND §22425, CHAPTER 22, ARTICLE 4, DIVISION 2 OF TITLE 5 GUAM CODE ANNOTATED (GCA) BY ADDING A NEW SUBSECTION (T) TO AUTHORIZE THE GOVERNOR TO BORROW FROM ANY LENDING INSTITUTION, INCLUDING BUT NOT LIMITED TO THE DEPARTMENT OF AGRICULTURE, RURAL DEVELOPMENT, GENERAL OBLIGATION LOANS FOR THE PURPOSE OF FUNDING THE COST OF DESIGN, PLANS AND CONSTRUCTION OF THE DEDEDO PRECINCT AND THE CRIME LAB OF THE GUAM POLICE DEPARTMENT AND TO APPROPRIATE SUCH FUNDS ACCORDINGLY.**

**Bill No. 685: AN ACT TO APPROPRIATE FUNDS TO THE DEPARTMENT OF PARKS AND RECREATION OFF-ISLAND SPORTS TRAVEL FUND TO SUBSIDIZE THE COST OF THE AIR TRAVEL FOR THE BASE RUTH AND THE BAMBINOS LITTLE LEAGUE.**

**Bill No. 686: AN ACT TO APPROPRIATE FROM THE VETERAN'S BONUS FUND TO THE NATIONAL ASSOCIATION FOR UNIFORMED SERVICES (NAUS) FOR THE COST TO REPAIR THE VANDALIZED NAUS MEMORIAL AT ASAN POINT DEDICATED TO THE FIGHTING MEN OF THE UNIFORMED SERVICES WHO GAVE THE SUPREME SACRIFICE FOR THE DEFENSE OF THEIR COUNTRY AND THE RECAPTURE OF GUAM DURING WWII.**

**BILL 687: AN ACT TO CLEARLY IDENTIFY A SOURCE OF FUNDS APPROPRIATED TO THE SUPERIOR COURT OF GUAM IN P.L. 24-139.**

**The Public is invited to attend and present written and/or oral testimony.  
Contact the Office of Vice-Speaker Anthony C. Blaz at 472-3557/58/60**

Public Hearing, Tuesday, July 7, 1998





+ 233

Route 114

221

233

Proposed  
S.V.S.

S.V.S.

LEUNG

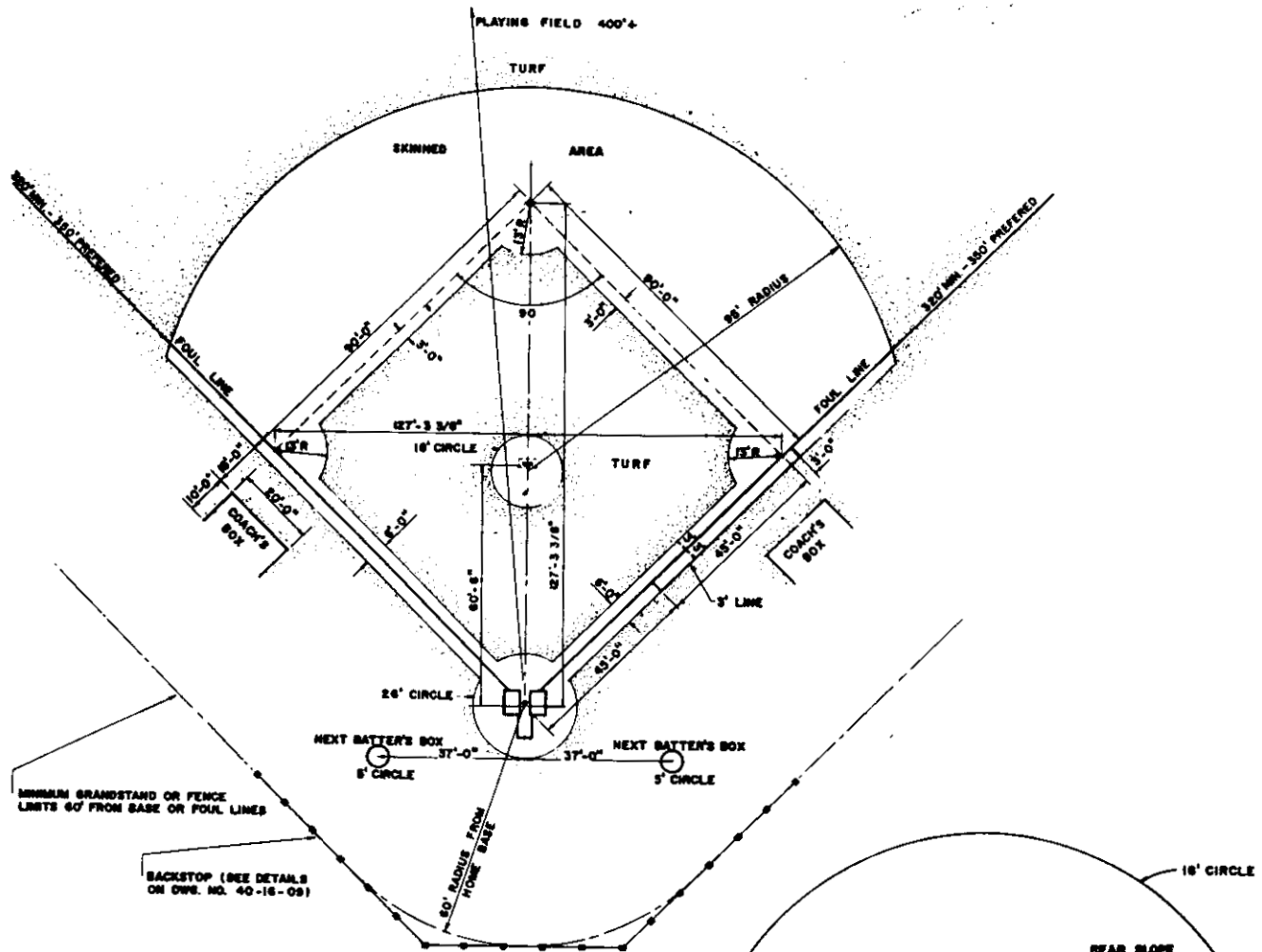

Figure 5.9 Baseball diamond.

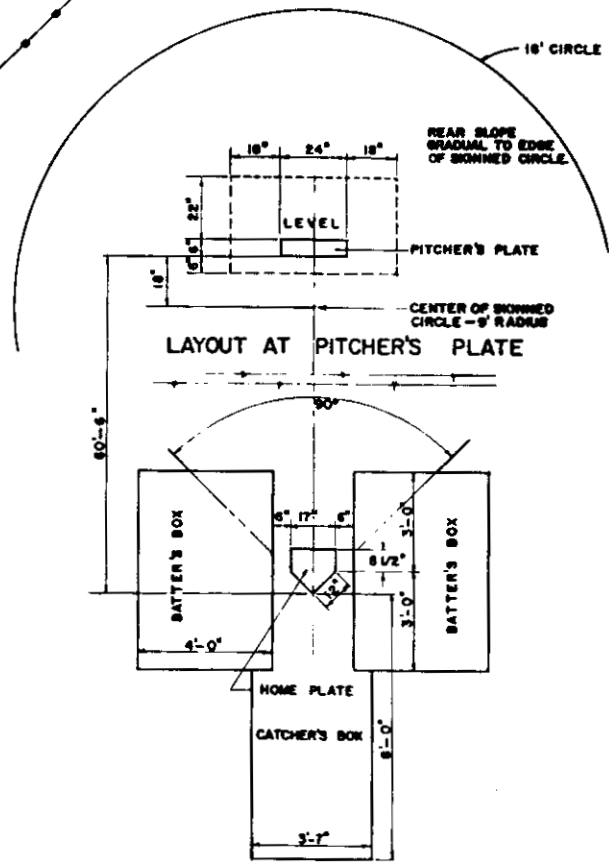

Figure 5.10 Layout at home and pitcher's plates.

Softball

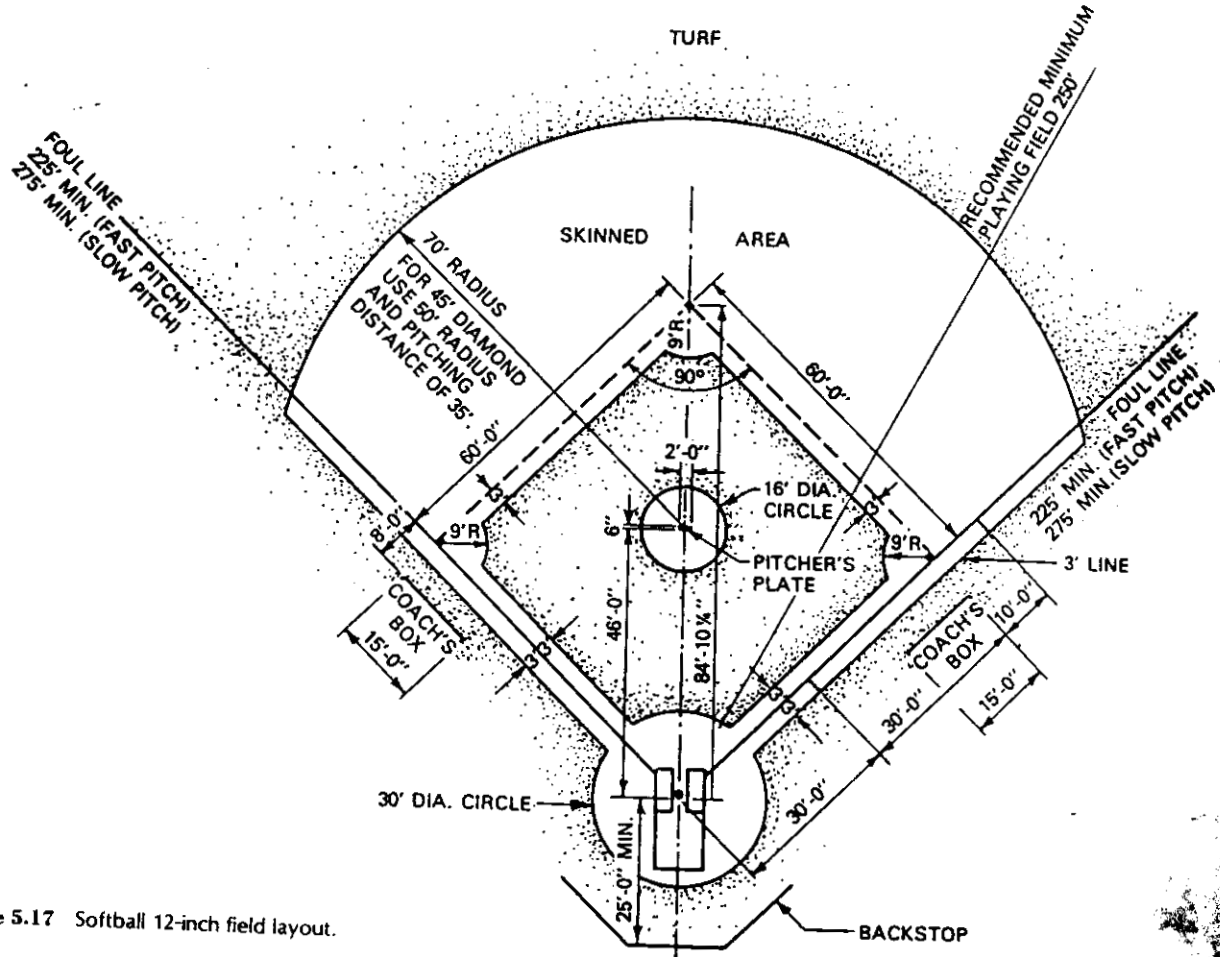

Figure 5.17 Softball 12-inch field layout.

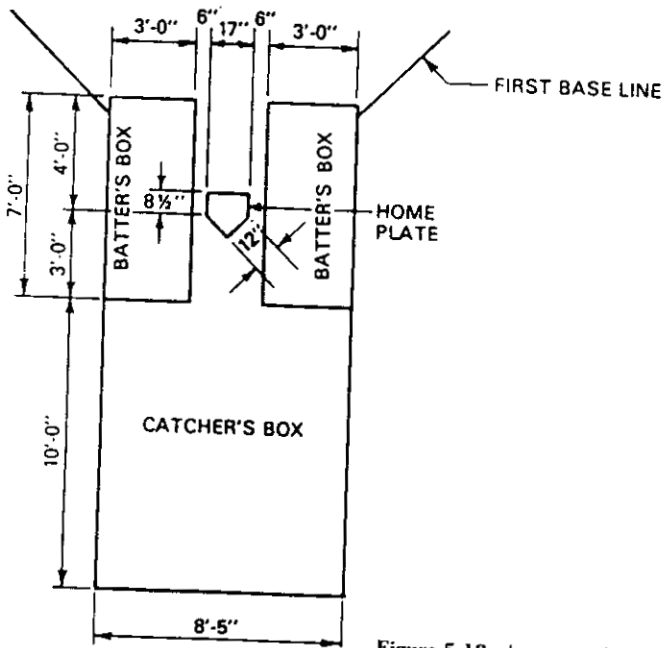

Figure 5.18 Layout at home plate.

5.2 LAYOUT OF GAMES AND SPORTS ACTIVITIES: TENNIS

Tennis A layout for two tennis courts is shown in Figure 5.23.

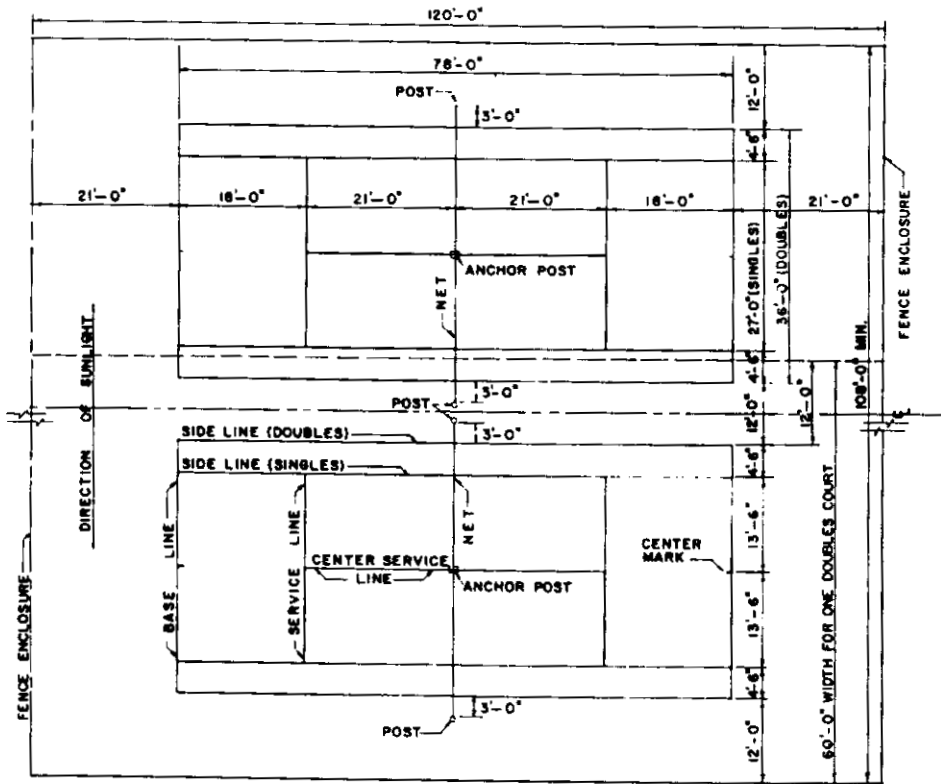

Figure 5.23 Tennis courts.

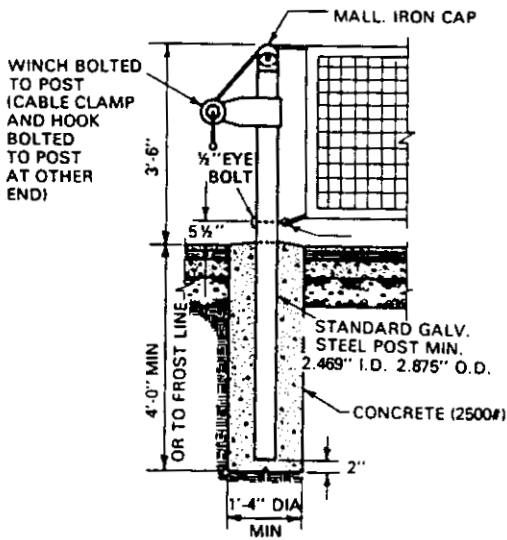

Figure 5.24 Tennis net and post details.

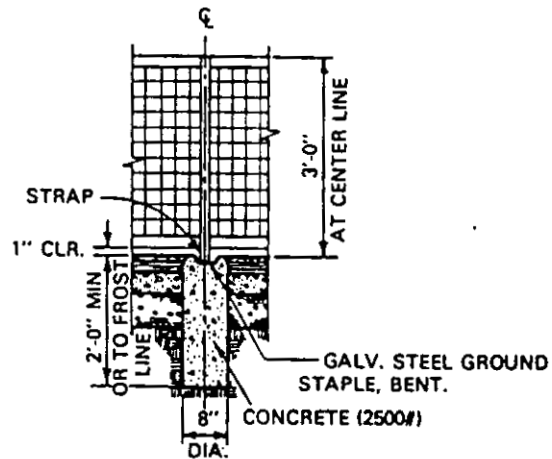

Figure 5.25 Anchor footing.